

Series 700 - Floor to Ceiling

1 Inspection

The components for this project have been custom fabricated. They are guaranteed with respect to manufacture and workmanship and were inspected at the factory. Before beginning work, the units should be inspected. If damage occurred in transit, report immediately to the freight company or other agencies that may have caused the damage.

2 Layout

- Review the shop drawings and packing lists that have accompanied this job.
- Before proceeding, confirm that backing of walls, ceiling and floor is adequate to support secure mounting of the toilet compartment units.
- Establish and mark pilaster center line from back wall.
- Establish and mark panel center lines for wall brackets.
- Establish pilaster floor & ceiling fastener locations from side wall according to shop drawings.
- Mark wall for bracket holes using single or double ear brackets as templates.

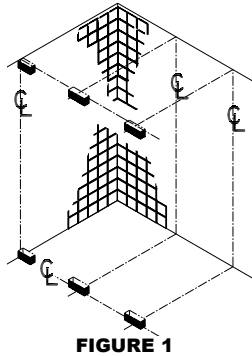

FIGURE 1

3 Wall, Ceiling & Floor Brackets

- Drill holes for wall brackets, floor & ceiling fasteners of appropriate size for fasteners supplied.
- Insert anchoring devices in walls and secure wall brackets.
- Insert expansion shields or other floor & ceiling fasteners and position 3/8" threaded rods at floor, secured with a shoe clip and anchor nut. At ceiling mount "L" angle with shoe clip and locking screw. See figure 5.

Measurements are from floor

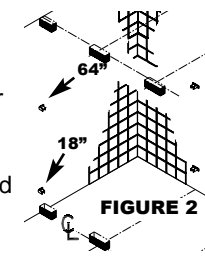

FIGURE 2

4 Position Panel

- Place panel on a support, 12" above the floor.
- Set it into wall brackets, but do not fasten panel at this time.

Measurements are from floor

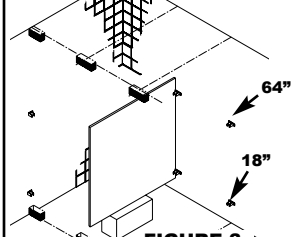

FIGURE 3

5 Pilaster Preparation

- Align U-brackets in position on rear of pilasters. Refer to layout drawings.
- Fasten U-brackets to pilasters with sheet metal screws.
- Pilasters at wall do not require U-brackets.

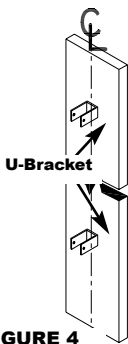

FIGURE 4

6 Install Pilasters

- Slide stainless steel shoe carefully over each end of the pilaster and leave approx. 5" of pilaster showing above and below shoe.
- At bottom, screw supporting nut and mounting washer on threaded rods then position the mounting bracket. Screw on locking nut. Loosely tighten into floor.
- Connect top of pilaster at ceiling to "L" angle with supporting screw.

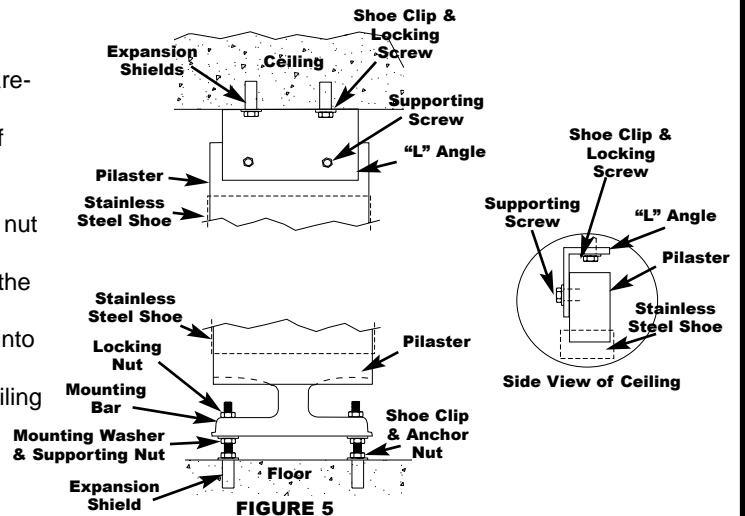

FIGURE 5

7 Securing Pilasters

- Pilasters must be both plumb and level.
- Plumb pilaster and fasten pilaster to panel using #14 x 5/8" machine screws.
 - Establish bottom door opening by setting pilaster mountings to desired position.

8 Panel Fastening & Shoe Positioning

- Level pilasters from one compartment to the next by adjusting support nuts on the threading rods. See figure 5.
- Tighten locking nuts on top of pilaster mounting bars.
- Slide stainless steel shoe down to floor level and up to the ceiling, firmly engaging shoe clips.
- Fasten panel to wall brackets using #14 x 5/8" machine screws.
- Remove panel support device.

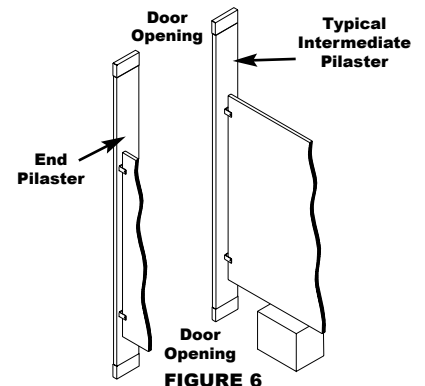

FIGURE 6

Series 700 - Floor to Ceiling continued

9 Hinge Assembly & Door Hanging

- A. Install top hinges to front pilasters.
- Note:** The hinge has nylon bushing with "MILLS" imprinted on it. Hinge must be installed in the top position.
- B. Install pin thru cam to bottom hinge as shown in figure 7. Put on nut but do not tighten at this time.
- C. Place door bottom onto bottom hinge pin. Tilt door and align door top with pilasters top hinge.
- D. Insert top hinge pin in top of door and through nylon bushing. Gently tap hinge pin until it is seated in tubular clip within door.
- E. Set door to desired position (30° opening recommended) and fully tighten nut on bottom hinge pin to set the position.

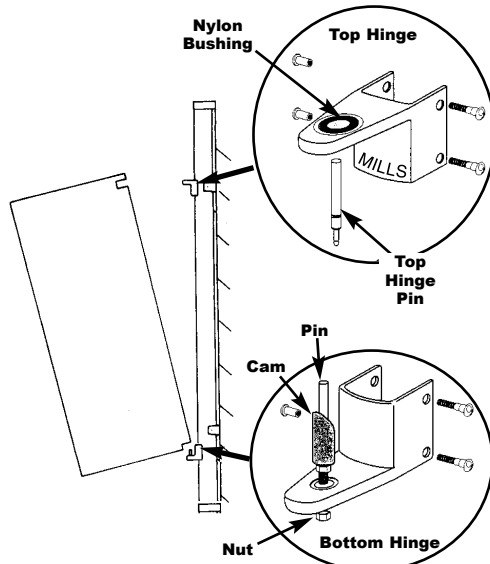

FIGURE 7

10 Concealed Latch Assembly

Install concealed latch-on door opposite the hinge side of door. All concealed latches should be mounted at midpoint of the door.

Inswing Doors

- A. Insert latch assy. (to inside of stall) and front escutcheon plate into door recess and secure in place with (2) #10-40 x 5/8" Torx head screws.
- B. Slide the knob on the latch assy. to the lock position. Insert lock bolt into the door end guide hole. Push the lock bolt in until end is located into the lock spring.
- C. Install bumper on front pilaster. Inswing - Black bumper visible from inside stall. Outswing - Black bumper visible from outside of stall.
- D. For outswing doors, install door pull on outside of door.

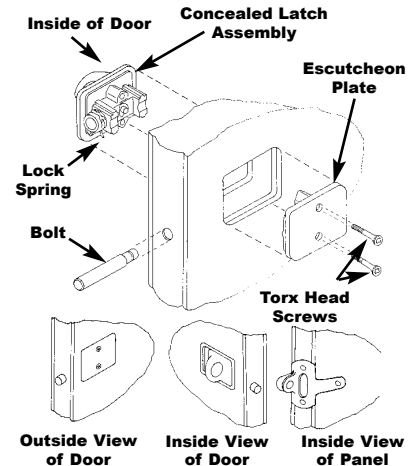

FIGURE 8

Emergency Access

Lift door causing latch bolt to clear keeper and open.

11 Miscellaneous Hardware

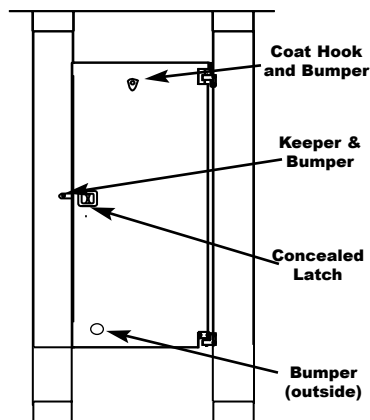

FIGURE 9 (inside view)

- A. Install coat hooks with rubber tips for inswing doors, inside center of door appr. 4" down from top. (Use coat hooks w/out rubber tips for outswing doors.)
- B. For ADA compartments mount door hook, center of door, 48" to 52" off of finished floor. (recommended only)
- C. Install door bumper for outswing doors on the outside of the door, lower corner opposite the hinge side or on adjacent wall.

12 Care & Maintenance of Toilet Partitions

In order to provide toilet partitions with the proper care and maintenance, the following instructions must be followed.

- A. All surfaces must be kept clean with water and a mild soap solution only. The finish must be wiped dry following cleaning.
- B. In high humidity areas, the rooms must be properly ventilated.
- C. Hosing down or wet washing of these units may cause water absorption and damage.
- D. For maximum protection periodic application of any standard furniture wax will be beneficial.

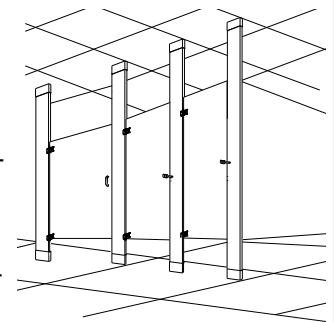

FIGURE 10

WARNING

Under no circumstances should these components be subjected to:

- Abrasive powders or pads - Water closet cleansers - Ceramic tile cleansers
- Solutions containing more than 1% by volume of ammonia
- Solutions containing acids or lye - Solutions containing enzymes

Attention to work progress during new construction or renovation is important. Other trades and cleaning services may use agents for ceramics and tiles that will damage these components.