



Technical Data

MATRIX™ SERIES SURFACE-MOUNTED SANITARY NAPKIN DISPOSAL

B-5270



Patented

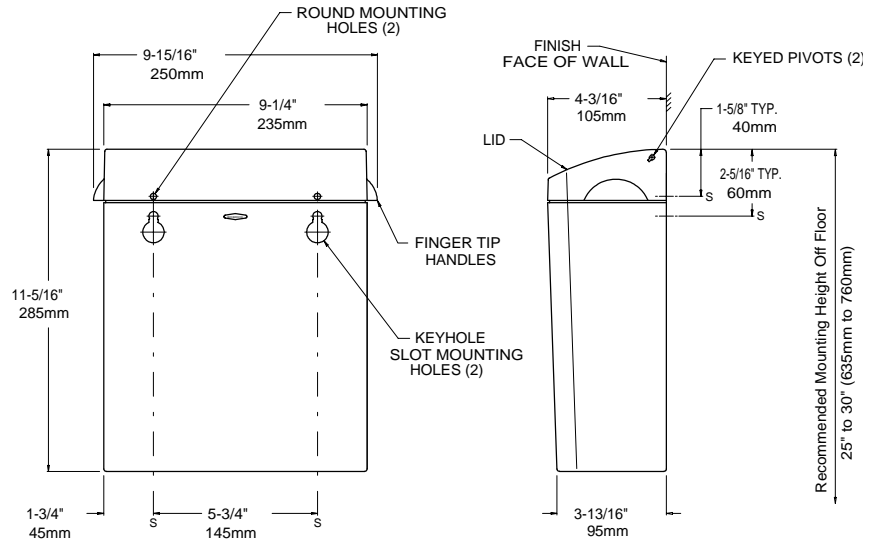

MATERIALS:

Container — Durable, high-impact grey ABS with high-gloss finish on exposed surfaces. Front of container has same degree of arc as front of lid and other Bobrick Matrix Series washroom accessories. Radius on corners and edges of container complement corners and edges of lid and other Matrix Series accessories.

Lid — Durable, high-impact grey ABS with high-gloss finish on exposed surfaces. Fingertip handles for opening lid. Front of lid has same degree of arc as front of container and other Bobrick Matrix Series washroom accessories. Radius on corners, edges and top of lid complement corners and edges of container and other Matrix Series accessories. Secured to container with keyed pivots.

OPERATION:

Lid flips up for disposal of sanitary napkins and for servicing container. Disposable paper liners for the container are available as an optional accessory: order Bobrick Part No. 270-12 (case of 1000 paper liners).

INSTALLATION:

For permanent installation, use upper round mounting holes. Mount unit with two sheet metal screws, furnished by manufacturer, at points indicated by an *S*.

For installation where the entire unit may be removed from wall for emptying and cleaning, use lower keyhole slot mounting holes. Using the container as a template, mark the location of the keyhole slots indicated by an *S*. Mount plastic bushings with screws furnished by manufacturer. Container then snaps over bushings to hold unit in place.

For plaster or dry wall construction, provide concealed backing to comply with local building codes, then secure unit with sheet-metal screws furnished by manufacturer.

For masonry walls, provide fiber plugs or expansion shields for use with sheet-metal screws furnished by manufacturer, or provide 3/16" (4.8mm) toggle bolts or expansion bolts.

For partitions with particle board or other solid core, secure with two sheet-metal screws (not furnished), or provide through-bolts, nuts, and washers.

For hollow-core metal partitions, provide solid backing into which sheet-metal screws (not furnished) can be secured. If two units are installed back-to-back, then provide threaded sleeves and machine screws for the full thickness of partition.

SPECIFICATION:

Surface-mounted sanitary napkin disposal shall be durable, high-impact grey ABS with high-gloss finish on exposed surfaces. Front of sanitary napkin disposal shall have same degree of arc and complement other Matrix™ Series accessories in the washroom. Radius on corners, edges and top of sanitary napkin disposal shall complement other Bobrick Matrix™ Series washroom accessories. Lid shall be secured to container with keyed pivots. Lid shall have fingertip handles. Replacement part numbers shall be molded into unit. Manufacturer's service and parts manual shall be provided to the building owner/manager upon completion of project.

Surface-Mounted Sanitary Napkin Disposal shall be Model B-5270 of Bobrick Washroom Equipment, Inc., Clifton Park, New York; Jackson, Tennessee; Los Angeles, California; Bobrick Washroom Equipment of Canada Ltd., Scarborough, Ontario; Bobrick Washroom Equipment Pty. Ltd., Australia; and Bobrick Washroom Equipment Limited, United Kingdom.